

# HYPONTECH Quick Installation Guide

H838-00001-01

EN



HPS-1500 / HPS-2000 / HPS-3000 / HPS-3680 / HPS-4000 / HPS-5000 / HPS-6000 / HPS-6500  
 HPS-1500D / HPS-2000D / HPS-3000D / HPS-3680D / HPS-4000D / HPS-5000D / HPS-6000D / HPS-6500D

## 1. Product Overview

1. LCD&LED or LED
2. DC switch (optional)
3. PV Terminal (s)
4. Wi-Fi/GPRS Stick(optional)
5. Cable gland for Meter/DRM
6. AC Terminal
7. Second PE Terminal

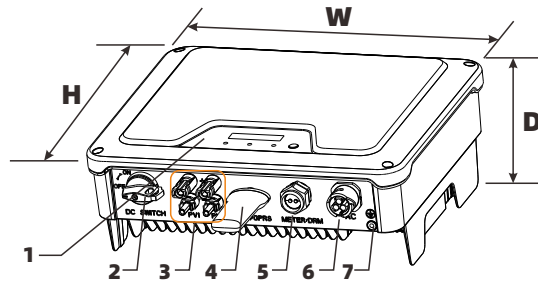

Dimension:W×H×D=395 x 328 x 154mm

## 2. Packing List

Inverter	Mounting Bracket	Mounting Accessories	DC Plugs (Sealed)	AC Connector	Wi-Fi stick (optional)	Documents
1	1	1	1*	1	1	1

\*2 pairs for HPS-3680/4000/5000/6000/6500 and HPS-3680D/4000D/5000D/6000D/6500D

## 3. Installing

### Installation Requirements

1. Please install the inverter(s) in places that can avoid inadvertent contact.
2. Please install the inverter on solid/smooth surfaces.
3. The inverter(s) should not be installed near inflammable or explosive objects.

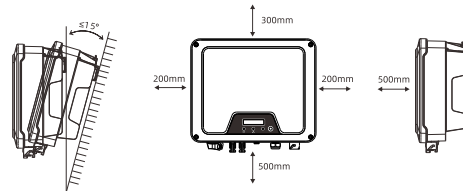

### AVOID



Direct Sunlight

Rain Exposure

Snow Lay up

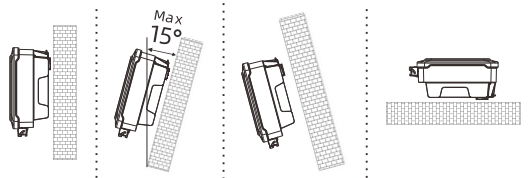

### Cable Specifications

No	Item	Type	Specifications
1	PE cable	Single-core outdoor copper cable	• Conductor cross-section: $\geq 4\text{mm}^2$
2	AC Output cable	Outdoor copper cable	• HPS-1.5~3kW - cross-section: 2.5-6 $\text{mm}^2$ • HPS-3.68~6.5kW - cross-section: 4-6 $\text{mm}^2$ • Cable outer diameter: 9-14 mm
3	DC Input cable	Standard outdoor PV cable, PVI-F Model recommended	• Conductor cross-section: 2.5-6 $\text{mm}^2$ • Cable outer diameter: 4.5-7.8 mm
4	Meter	Two-core outdoor shielded twisted pair cable	• Conductor cross-section: 0.14-1.5 $\text{mm}^2$ • Cable outer diameter: approx. 9 mm
5	DRED	CAT-5E, outdoor shielded cable Standard for EIA/TIA 568B	• Cable outer diameter: approx. 9 mm • cable maximum length 1000m

## 3.1 Mounting

- 3.1.1 Use the mounting bracket as a template and drill holes of 10mm diameter and 70mm depth
- 3.1.2 Fix the mounting bracket with the screws and expansion bolts packed in mounting accessories
- 3.1.3 Attach the inverter to the mounting bracket
- 3.1.4 Check both sides of heat sink and ensure the inverter is stably attached
- 3.1.5 Use M5 screws (with T25 screwdriver, torque: 2.5Nm) to attach the heat sink fins to the mounting bracket
- 3.1.6 It is recommended to attach an anti-theft lock to the inverter

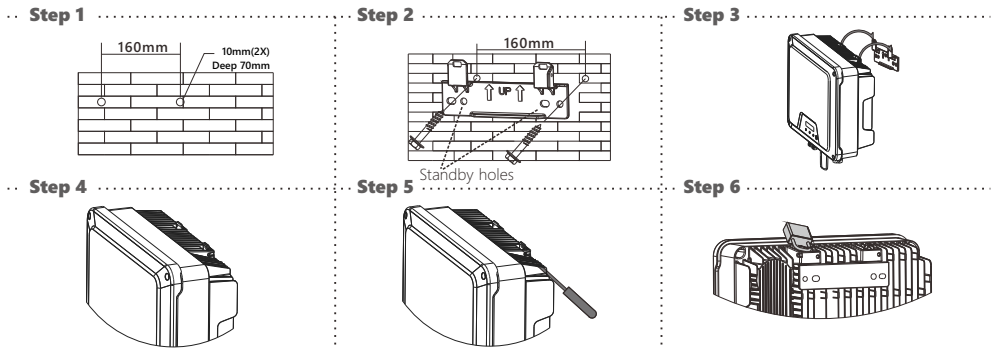

## 3.2 Installing the PE Cable

A second PE terminal is equipped at the bottom of the inverter. Ensure the PE terminal is reliably grounded and the grounding resistance is less than 10 Ohm.

Object	Description
1	Housing
2	M5 terminal lug with protective conductor
3	M5×13 pan head screw

Tighten it firmly into the housing (T25 screwdriver, torque: 2.5Nm).

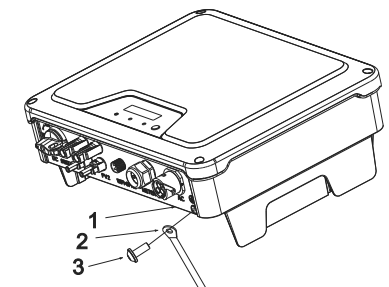

### NOTICE

Proper grounding connection of the second PE terminal and the AC terminal is mandatory. NOT properly connecting both PE will void all product warranty.

## 3.2 AC Wire Assembly and Connection

### **DANGER**

#### Danger to Life due to High Voltages in the Inverter

Before connecting any electrical wires and components, please ensure the DC switch & AC circuit breaker are switched OFF and cannot be reactivated.

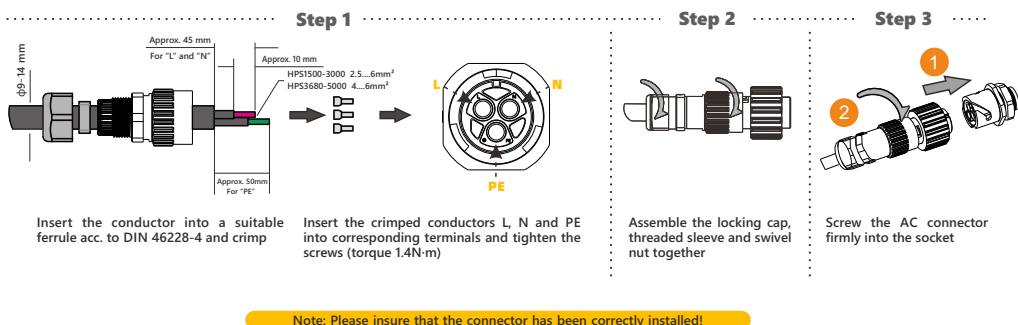

## 3.3 DC Wire Assembly and Connection

Meeting the following requirements is mandatory. All warranty rights will otherwise be invalid.

- 3.3.1 Maximum open voltage of each string is less than 600V.
- 3.3.2 Maximum short circuit current of each PV input is less than inverter allowable limit.
- 3.3.3 The string is well insulated to ground in all cases.
- 3.3.4 Make sure that the DC connectors have the correct polarity.
- 3.3.5 If the PV connectors are not assembled properly and locked into place, arc or overheat may be induced.

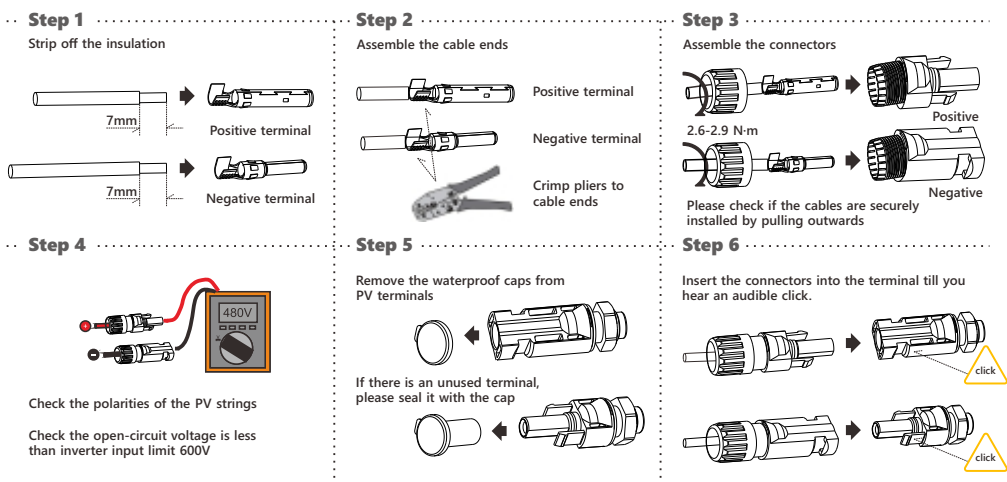

## 3.4 Wi-Fi Connection (Optional)

The Wi-Fi stick is included in the scope of delivery as an option.

- 3.4.1 Tighten the Wi-Fi stick into the Wi-Fi connection port by hand. Make sure the Wi-Fi stick is securely connected.
- 3.4.2 For the connection and configuration of the Wi-Fi stick please refer to <Wi-Fi stick User manual> .

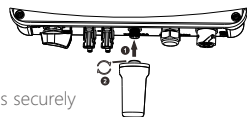

## 3.5 Smart Meter and DRED Connection

Smart meter and DRED connection as following steps.

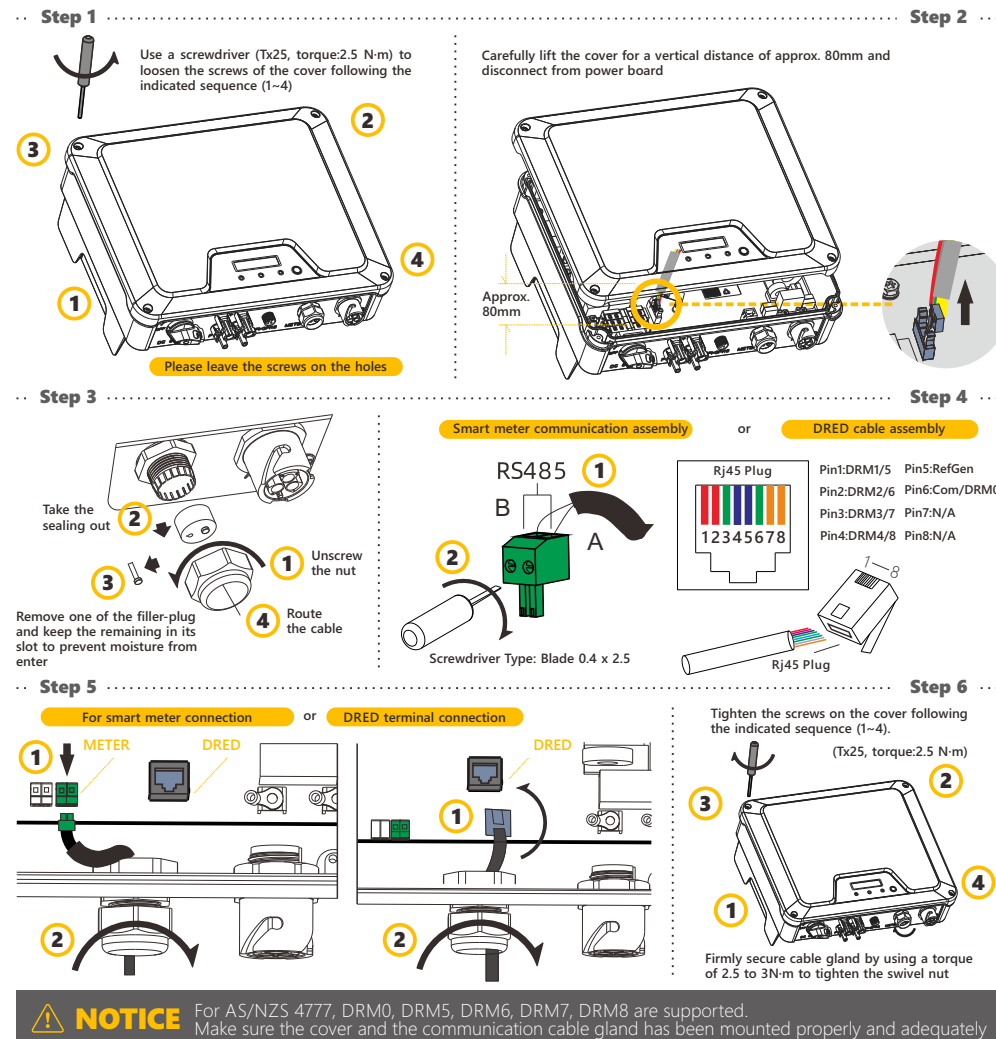

## 4. Commissioning

Please check if

1. The inverter and mounting bracket have been correctly installed.
2. The inverter's exposed metal surface has a ground connection.
3. The resistance between PV arrays and ground is greater than 1Mohm.
4. For any unused DC terminals, there are DC connectors inserted to the terminal and sealed with waterproof caps.
5. The grid voltage at the point of connection of the inverter is within the permitted range.
6. The AC circuit breaker must be correctly rated and wired.
7. The cable communication connectors have been correctly wired and tightened.

Startup

Switch on the DC switch after finishing the above checks, then switch on the AC circuit breaker. When there is sufficient DC power applied and the grid conditions are met, the inverter will start to operate automatically.

Warranty card will be shipped with inverter. Download of current warranty conditions is available at <https://www.hypontech.com>  
Suzhou Hypontech Co.,Ltd / Tel.: +86 0512-80712199 / Fax: +86 0512-80712382 / Web: [www.hypontech.com](http://www.hypontech.com)  
Address: No.588 Wutaishan Road, SND, Suzhou, China  
For more information, please download the user manual and other technical documents at <https://www.hypontech.com/downloads.html>